

# THE BIG IDEA

Any path along  
which electrons can  
flow is a circuit.

**Mechanical things seem to be easier to figure out for most people than electrical things. Maybe this is because most people have had experience playing with blocks and mechanical toys. Hands-on laboratory experience aids your understanding of electric circuits. The experience can be a lot of fun, too!**



## 35.1 A Battery and a Bulb



**In a flashlight, when the switch is turned on to complete an electric circuit, the mobile conduction electrons already in the wires and the filament begin to drift through the circuit.**

## 35.1 A Battery and a Bulb

A flashlight consists of a reflector cap, a light bulb, batteries, and a barrel-shaped housing with a switch.

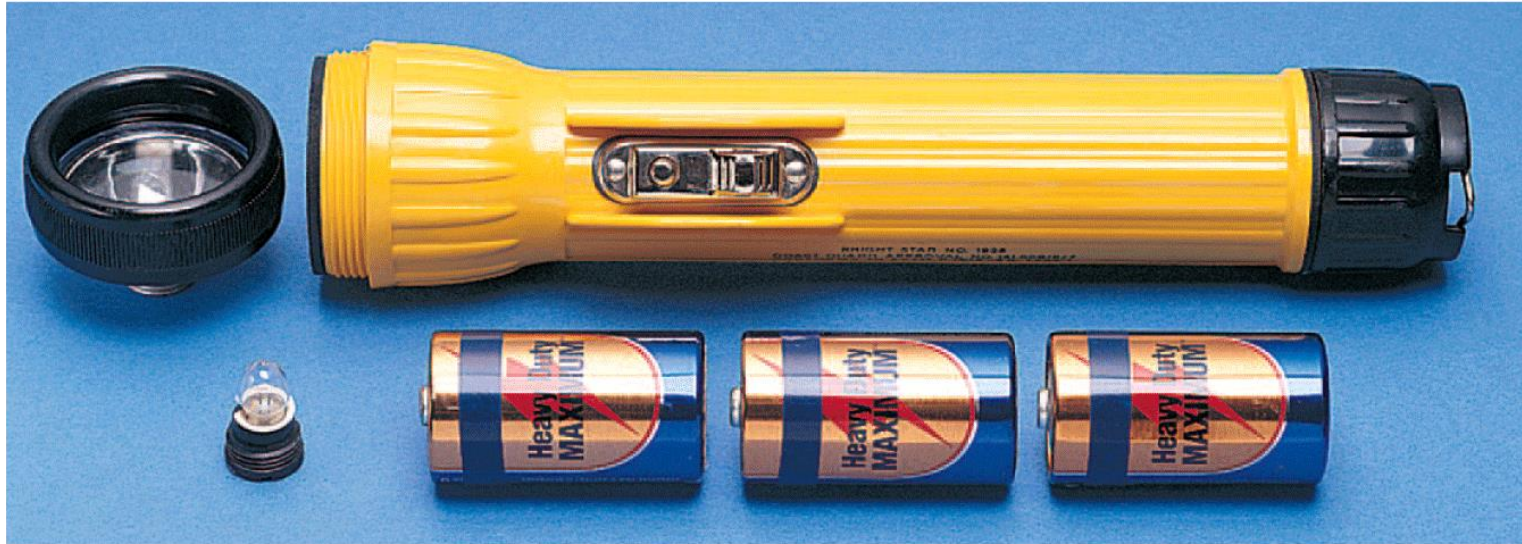



## 35.1 A Battery and a Bulb

There are several ways to connect the battery and bulb from a flashlight so that the bulb lights up.

The important thing is that there must be a complete path, or **circuit**, that

- includes the bulb filament
- runs from the positive terminal at the top of the battery
- runs to the negative terminal at the bottom of the battery

## 35.1 A Battery and a Bulb

Electrons flow

- from the negative part of the battery through the wire
- to the side (or bottom) of the bulb
- through the filament inside the bulb
- out the bottom (or side)
- through the wire to the positive part of the battery

The current then passes through the battery to complete the circuit.

## 35.1 A Battery and a Bulb

a. Unsuccessful ways to light a bulb.

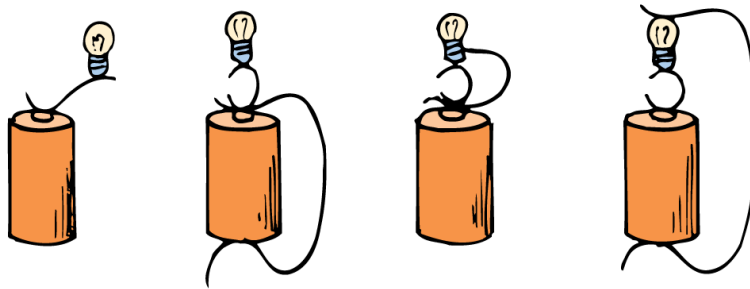

a

## 35.1 A Battery and a Bulb

- Unsuccessful ways to light a bulb.
- Successful ways to light a bulb.

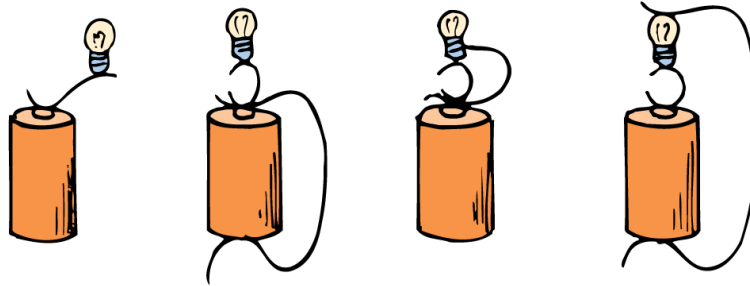

**a**

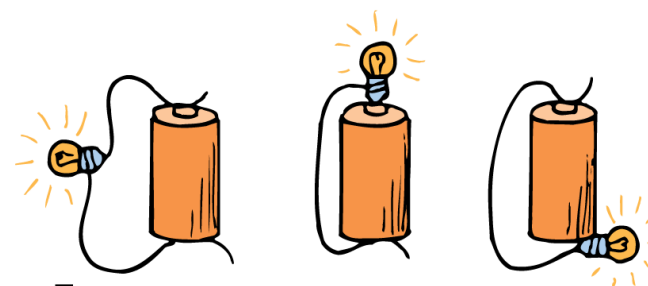

**b**



## 35.1 A Battery and a Bulb

The flow of charge in a circuit is very much like the flow of water in a closed system of pipes.

In a flashlight, the battery is analogous to a pump, the wires are analogous to the pipes, and the bulb is analogous to any device that operates when the water is flowing.

When a valve in the line is opened and the pump is operating, water already in the pipes starts to flow.

## 35.1 A Battery and a Bulb

Neither the water nor the electrons concentrate in certain places.

They flow continuously around a loop, or circuit.

When the switch is turned on, the mobile conduction electrons in the wires and the filament begin to drift through the circuit.

Filament resistance in a 120-V, 60-W bulb increases about 15 times from room temperature to its nearly 3000-K operating temperature in a time of about 100 milliseconds. The initial 10-A current drawn quickly decreases to a steady 0.7 A.



## 35.1 A Battery and a Bulb

Electrons do not pile up inside a bulb, but instead flow through its filament.

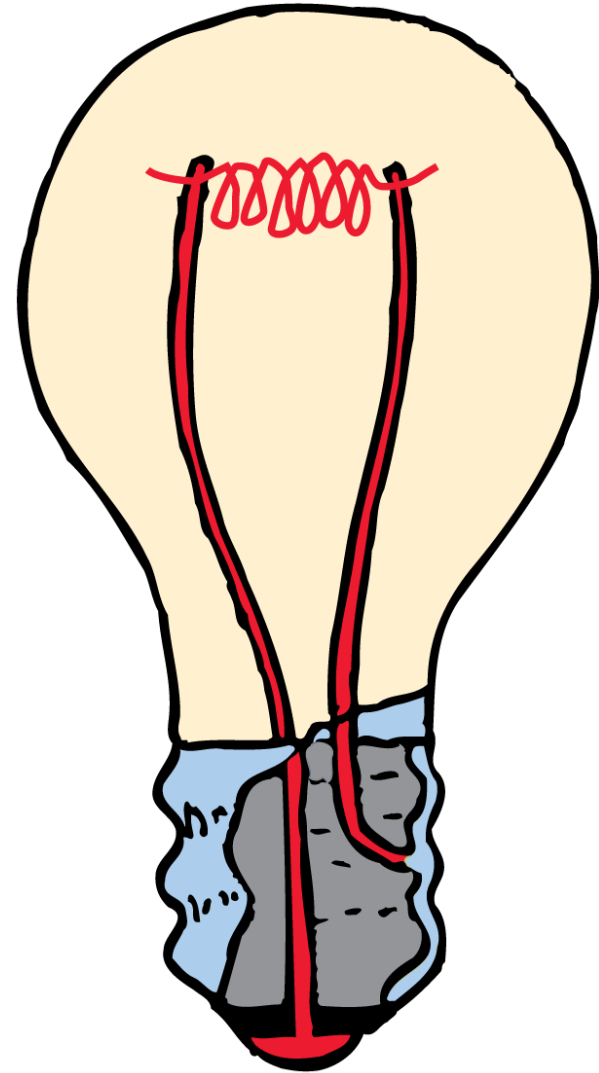

## 35.1 A Battery and a Bulb

**CONCEPT  
CHECK**

What happens to the mobile conduction electrons when you turn on a flashlight?

## 35.2 Electric Circuits



**For a continuous flow of electrons, there must be a complete circuit with no gaps.**



## 35.2 Electric Circuits

Any path along which electrons can flow is a circuit.

A gap is usually provided by an electric switch that can be opened or closed to either cut off or allow electron flow.

After failing more than 6000 times before perfecting the first electric lightbulb, Thomas Edison stated that his trials were not failures, because he successfully discovered 6000 ways that don't work.

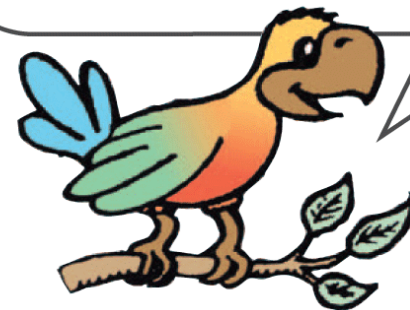

## 35.2 Electric Circuits

The water analogy is useful but has some limitations.

- A break in a water pipe results in a leak, but a break in an electric circuit results in a complete stop in the flow.
- Opening a switch stops the flow of electricity. An electric circuit must be closed for electricity to flow. Opening a water faucet, on the other hand, starts the flow of water.

## 35.2 Electric Circuits

Most circuits have more than one device that receives electrical energy.

These devices are commonly connected in a circuit in one of two ways, *series* or *parallel*.

- When connected **in series**, the devices in a circuit form a single pathway for electron flow.
- When connected **in parallel**, the devices in a circuit form branches, each of which is a separate path for electron flow.

## 35.2 Electric Circuits

**CONCEPT  
CHECK**

How can a circuit achieve a continuous flow of electrons?

## 35.3 Series Circuits



**If one device fails in a series circuit, current in the whole circuit ceases and none of the devices will work.**



## 35.3 Series Circuits

If three lamps are connected in series with a battery, they form a **series circuit**. Charge flows through each in turn.

When the switch is closed, a current exists almost immediately in all three lamps.

The current does not “pile up” in any lamp but flows *through* each lamp. Electrons in all parts of the circuit begin to move at once.

## 35.3 Series Circuits

Eventually the electrons move all the way around the circuit.

A break anywhere in the path results in an open circuit, and the flow of electrons ceases.

Burning out of one of the lamp filaments or simply opening the switch could cause such a break.

## 35.3 Series Circuits

In this simple series circuit, a 9-volt battery provides 3 volts across each lamp.

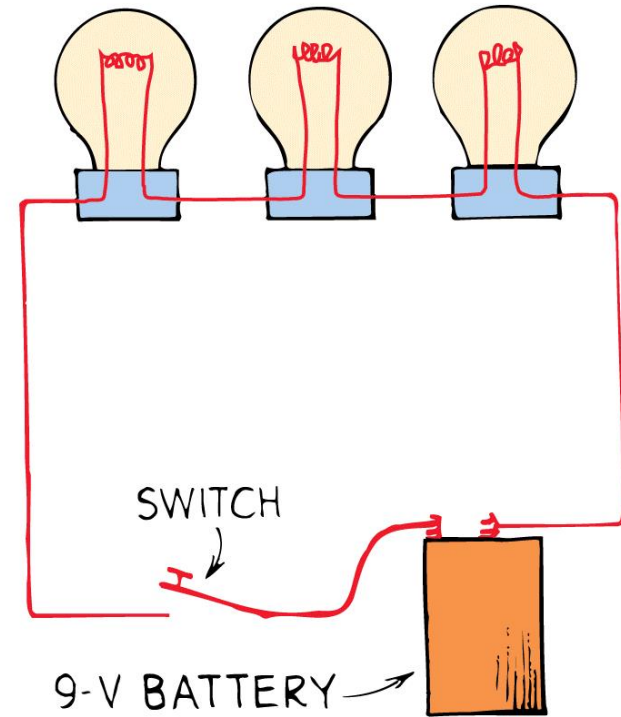

## 35.3 Series Circuits

For series connections:

- Electric current has a single pathway through the circuit.
- The total resistance to current in the circuit is the sum of the individual resistances along the circuit path.
- The current is equal to the voltage supplied by the source divided by the total resistance of the circuit. This is Ohm's law.
- The *voltage drop*, or potential difference, across each device depends directly on its resistance.
- The sum of the voltage drops across the individual devices is equal to the total voltage supplied by the source.

## 35.3 Series Circuits

The main disadvantage of a series circuit is that when one device fails, the current in the whole circuit stops.

Some cheap light strings are connected in series. When one lamp burns out, you have to replace it or no lights work.

A series circuit is like a single-lane road with no alternate path. If there is a roadblock or cave-in, traffic will stop.

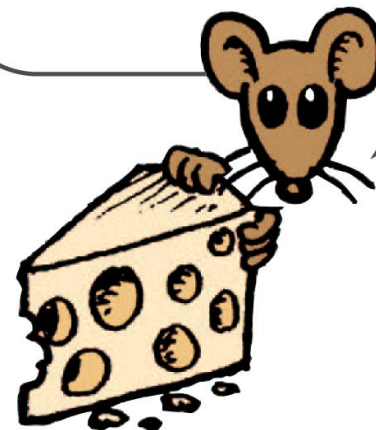



## 35.3 Series Circuits

### think!

What happens to the light intensity of each lamp in a series circuit when more lamps are added to the circuit?

## 35.3 Series Circuits

### think!

What happens to the light intensity of each lamp in a series circuit when more lamps are added to the circuit?

### Answer:

The addition of more lamps results in a greater circuit resistance. This decreases the current in the circuit (and in each lamp), which causes dimming of the lamps.

## 35.3 Series Circuits

### think!

A series circuit has three bulbs. If the current through one of the bulbs is 1 A, can you tell what the current is through each of the other two bulbs? If the voltage across bulb 1 is 2 V, and across bulb 2 is 4 V, what is the voltage across bulb 3?

## 35.3 Series Circuits

### think!

A series circuit has three bulbs. If the current through one of the bulbs is 1 A, can you tell what the current is through each of the other two bulbs? If the voltage across bulb 1 is 2 V, and across bulb 2 is 4 V, what is the voltage across bulb 3?

### Answer:

The same current, 1 A, passes through every part of a series circuit. Each coulomb of charge has 9 J of electrical potential energy ( $9 \text{ V} = 9 \text{ J/C}$ ). If it spends 2 J in one bulb and 4 in another, it must spend 3 J in the last bulb.  $3 \text{ J/C} = 3 \text{ V}$

## 35.3 Series Circuits

### CONCEPT CHECK

What happens to current in other lamps if one lamp in a series circuit burns out?



## 35.4 Parallel Circuits



**In a parallel circuit, each device operates independent of the other devices. A break in any one path does not interrupt the flow of charge in the other paths.**

## 35.4 Parallel Circuits

In a **parallel circuit** having three lamps, each electric device has its own path from one terminal of the battery to the other.

There are separate pathways for current, one through each lamp.

In contrast to a series circuit, the parallel circuit is completed whether all, two, or only one lamp is lit.

A break in any one path does not interrupt the flow of charge in the other paths.

## 35.4 Parallel Circuits

In this parallel circuit, a 9-volt battery provides 9 volts across each activated lamp. (Note the open switch in the lower branch.)

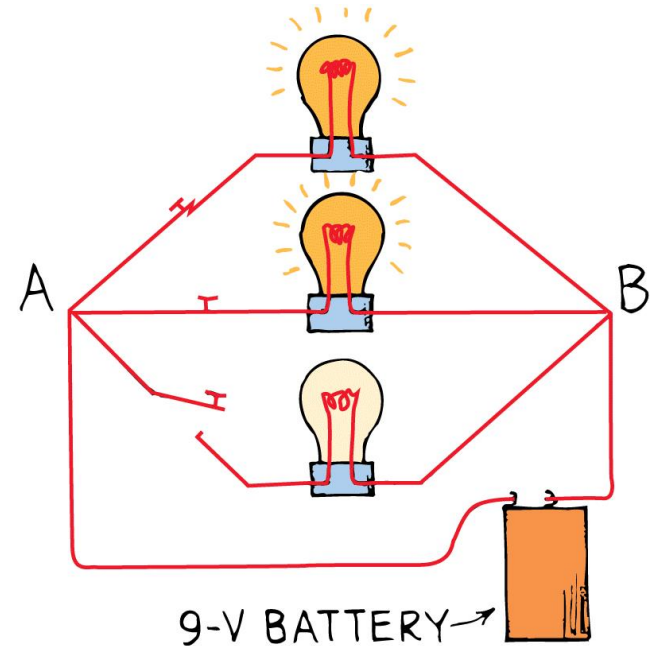
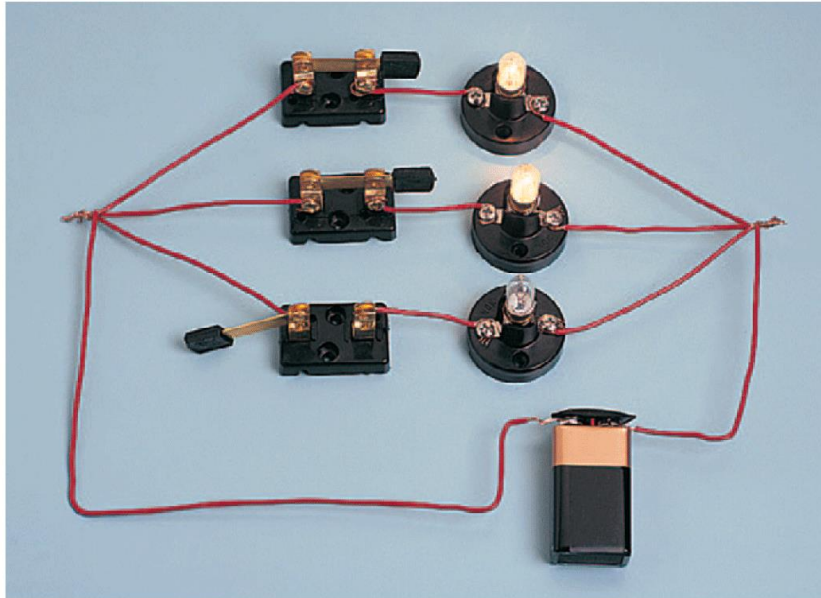

## 35.4 Parallel Circuits

Major characteristics of parallel connections:

- Each device connects the same two points A and B of the circuit. The voltage is therefore the same across each device.
- The total current divides among the parallel branches.
- The amount of current in each branch is inversely proportional to the resistance of the branch.
- The total current is the sum of the currents in its branches.
- As the number of parallel branches is increased, the total current through the battery increases.

## 35.4 Parallel Circuits

From the battery's perspective, the overall resistance of the circuit is *decreased*.

This means the overall resistance of the circuit is less than the resistance of any one of the branches.

## 35.4 Parallel Circuits

**think!**

What happens to the light intensity of each lamp in a parallel circuit when more lamps are added in parallel to the circuit?

## 35.4 Parallel Circuits

### think!

What happens to the light intensity of each lamp in a parallel circuit when more lamps are added in parallel to the circuit?

### Answer:

The light intensity for each lamp is unchanged as other lamps are introduced (or removed). Although changes of resistance and current occur for the circuit as a whole, no changes occur in any individual branch in the circuit.



## 35.4 Parallel Circuits

**CONCEPT  
CHECK**

What happens if one device in a parallel circuit fails?

## 35.5 Schematic Diagrams



In a schematic diagram, resistance is shown by a zigzag line, and ideal resistance-free wires are shown with solid straight lines. A battery is represented with a set of short and long parallel lines.

## 35.5 Schematic Diagrams

Electric circuits are frequently described by simple diagrams, called **schematic diagrams**.

- Resistance is shown by a zigzag line, and ideal resistance-free wires are shown with solid straight lines.
- A battery is shown by a set of short and long parallel lines, the positive terminal with a long line and the negative terminal with a short line.

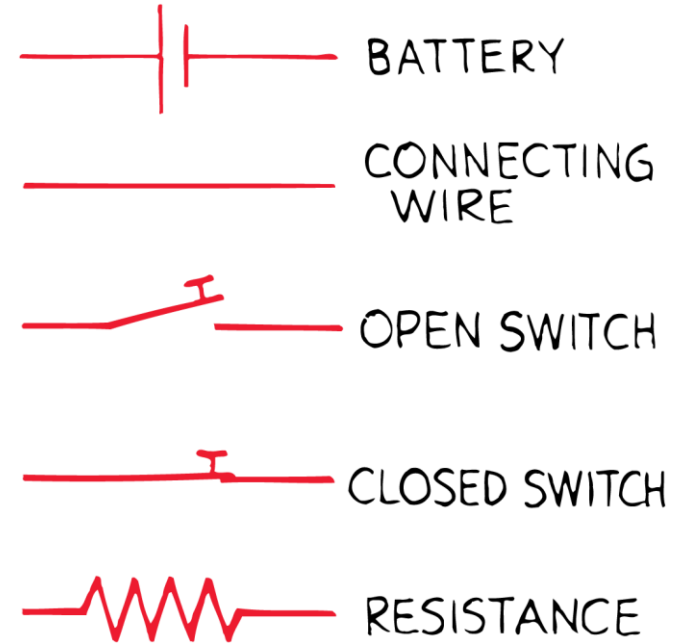

## 35.5 Schematic Diagrams

These schematic diagrams represent

- a circuit with three lamps in series, and

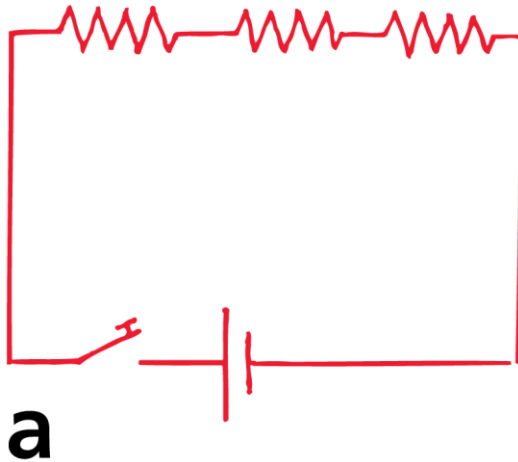

## 35.5 Schematic Diagrams

These schematic diagrams represent

- a circuit with three lamps in series, and
- a circuit with three lamps in parallel.

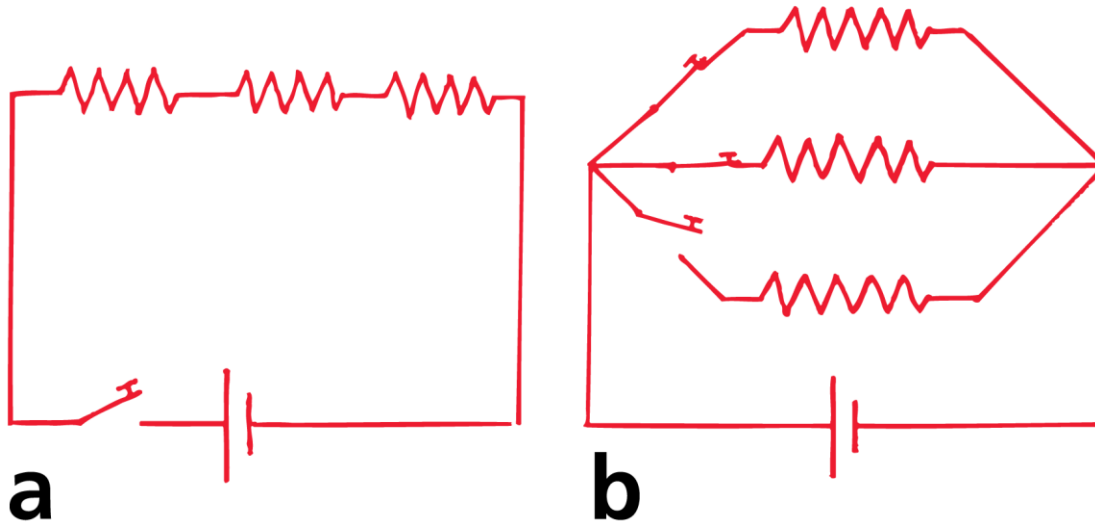

## 35.5 Schematic Diagrams

**CONCEPT:  
CHECK:**

What symbols are used to represent resistance, wires, and batteries in schematic diagrams?

## 35.6 Combining Resistors in a Compound Circuit



The equivalent resistance of resistors connected in series is the sum of their values. The equivalent resistance for a pair of equal resistors in parallel is half the value of either resistor.



## 35.6 Combining Resistors in a Compound Circuit

Sometimes it is useful to know the *equivalent resistance* of a circuit that has several resistors in its network.

The equivalent resistance is the value of the single resistor that would comprise the same load to the battery or power source.

The equivalent resistance of resistors connected in series is the sum of their values. For example, the equivalent resistance for a pair of 1-ohm resistors in series is simply 2 ohms.

## 35.6 Combining Resistors in a Compound Circuit

The equivalent resistance for a pair of equal resistors in parallel is half the value of either resistor.

The equivalent resistance for a pair of 1-ohm resistors in parallel is 0.5 ohm.

The equivalent resistance is *less* because the current has “twice the path width” when it takes the parallel path.

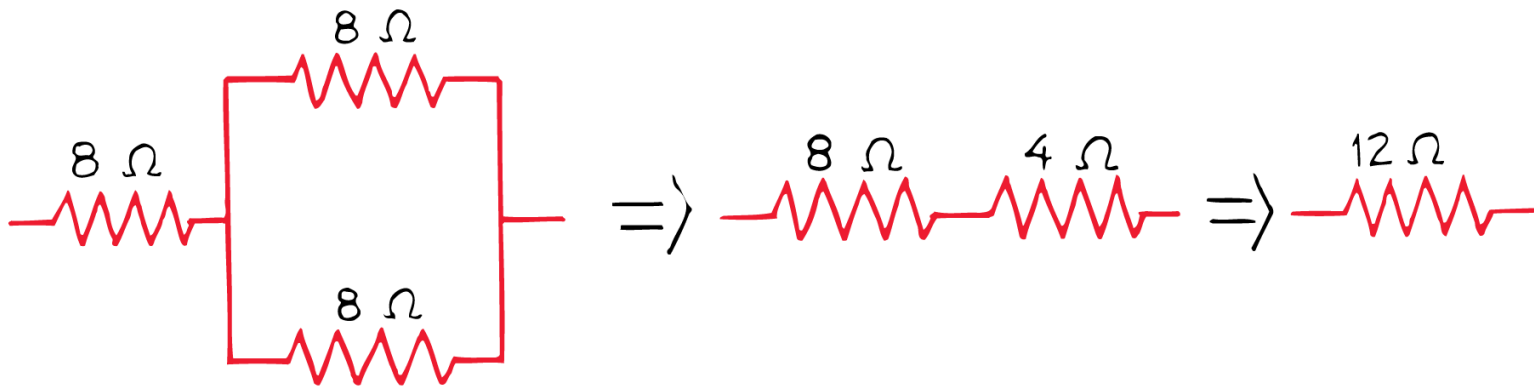

## 35.6 Combining Resistors in a Compound Circuit

- a. The equivalent resistance of two 8-ohm resistors in series is 16 ohms.



## 35.6 Combining Resistors in a Compound Circuit

- The equivalent resistance of two 8-ohm resistors in series is 16 ohms.
- The equivalent resistance of two 8-ohm resistors in parallel is 4 ohms.

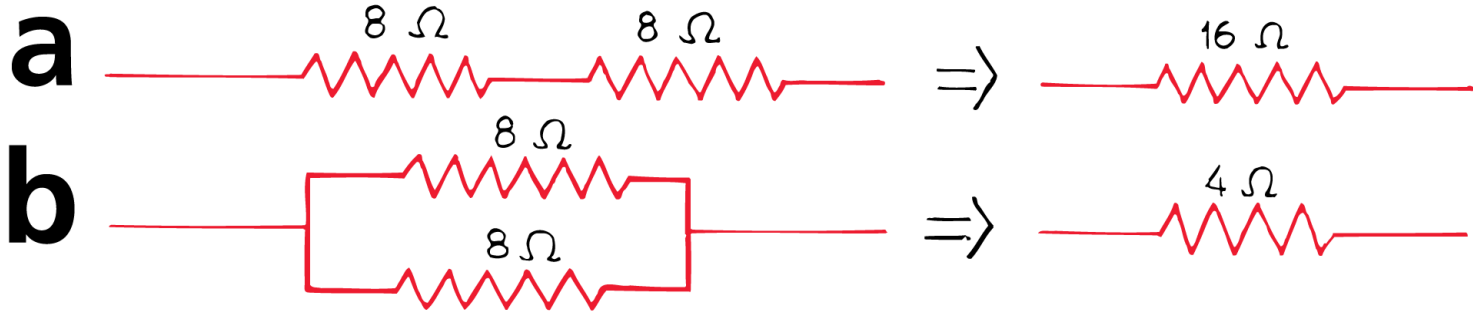

## 35.6 Combining Resistors in a Compound Circuit

For the combination of three 8-ohm resistors, the two resistors in parallel are equivalent to a single 4-ohm resistor.

They are in series with an 8-ohm resistor, adding to produce an equivalent resistance of 12 ohms.

If a 12-volt battery were connected to these resistors, the current through the battery would be 1 ampere.

(In practice it would be less, for there is resistance inside the battery as well, called the battery's *internal resistance*.)

## 35.6 Combining Resistors in a Compound Circuit

Schematic diagrams for an arrangement of various electric devices. The equivalent resistance of the circuit is 10 ohms.

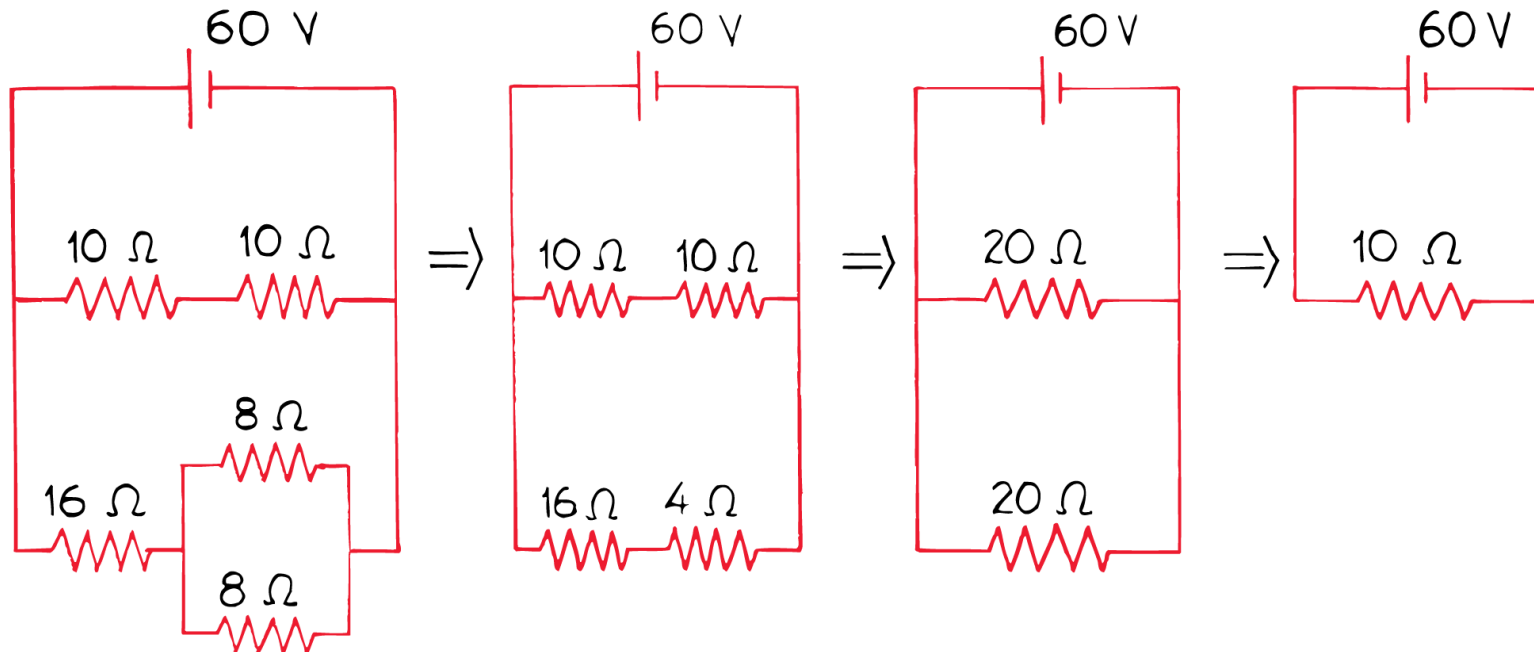

## 35.6 Combining Resistors in a Compound Circuit

### think!

In the circuit shown below, what is the current in amperes through the pair of 10-ohm resistors? Through *each* of the 8-ohm resistors?

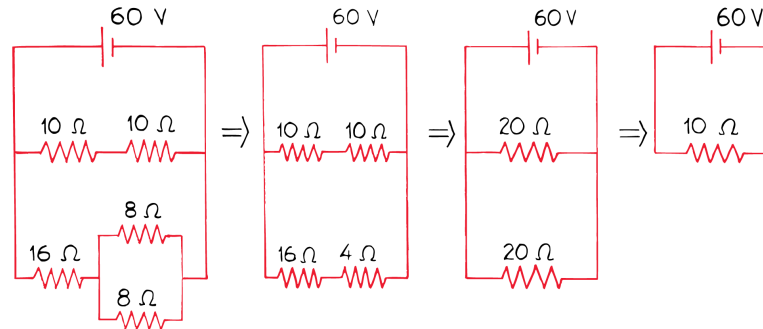



## 35.6 Combining Resistors in a Compound Circuit

### think!

In the circuit shown below, what is the current in amperes through the pair of 10-ohm resistors? Through *each* of the 8-ohm resistors?

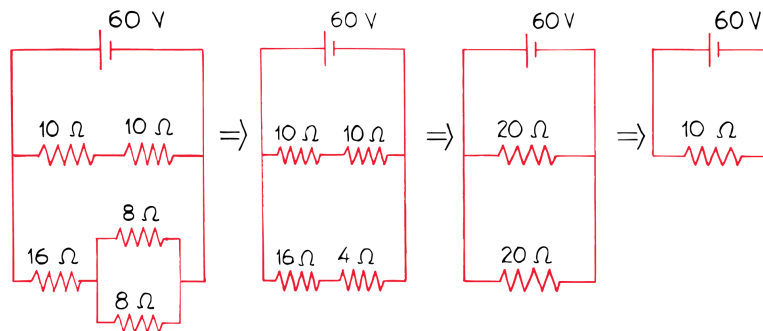

### Answer:

The total resistance of the middle branch is  $20\ \Omega$ . Since the voltage is  $60\ \text{V}$ , the current = (voltage)/(resistance) =  $(60\text{V})/(20\ \Omega) = 3\ \text{A}$ . The current through the pair of  $8\text{-}\Omega$  resistors is  $3\ \text{A}$ , and the current through each is therefore  $1.5\ \text{A}$ .

## 35.6 Combining Resistors in a Compound Circuit

### CONCEPT CHECK

What is the equivalent resistance of resistors in series? Of equal resistors in parallel?

## 35.7 Parallel Circuits and Overloading



To prevent overloading in circuits, fuses or circuit breakers are connected in series along the supply line.

## 35.7 Parallel Circuits and Overloading

Electric current is fed into a home by two wires called *lines*. About 110 to 120 volts are impressed on these lines at the power utility.

These lines are very low in resistance and are connected to wall outlets in each room.

The voltage is applied to appliances and other devices that are connected in parallel by plugs to these lines.

## 35.7 Parallel Circuits and Overloading

As more devices are connected to the lines, more pathways are provided for current.

The additional pathways lower the combined resistance of the circuit. Therefore, a greater amount of current occurs in the lines.

Lines that carry more than a safe amount of current are said to be *overloaded*, and may heat sufficiently to melt the insulation and start a fire.

## 35.7 Parallel Circuits and Overloading

Consider a line connected to a toaster that draws 8 amps, a heater that draws 10 amps, and a lamp that draws 2 amps.

- If the toaster is operating, the total line current is 8 amperes.
- When the heater is also operating, the total line current increases to 18 amperes.
- If you turn on the lamp, the line current increases to 20 amperes.

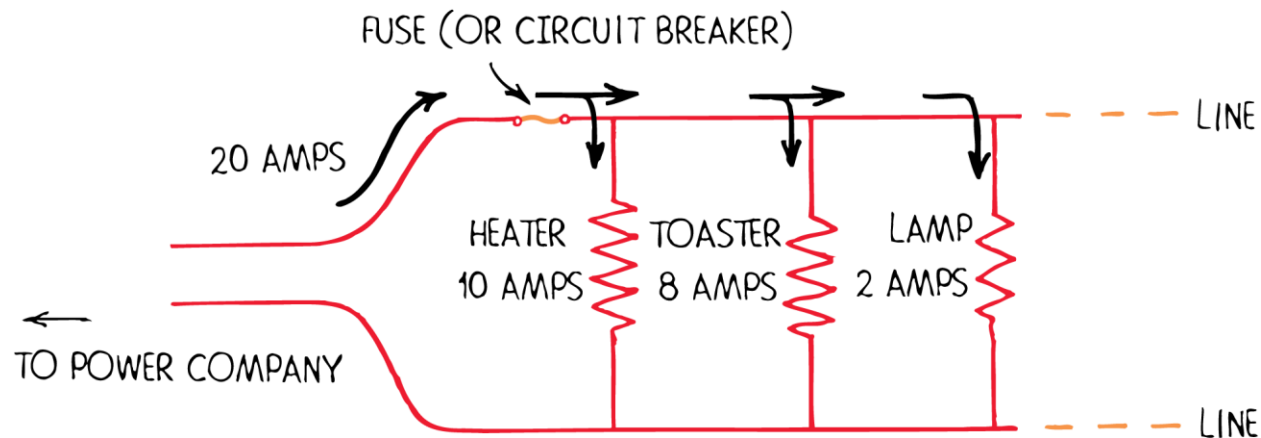

In practice, the lines in your home are not perfect conductors. With the large current used to operate a vacuum cleaner, the connecting wires do warm up. But for most cases, the resistance of the lines can be neglected.



## 35.7 Parallel Circuits and Overloading

To prevent overloading in circuits, fuses or circuit breakers are connected in series along the supply line.

The entire line current must pass through the fuse.

If the fuse is rated at 20 amperes, it will pass up to 20 amperes.

A current above 20 amperes will melt the fuse ribbon, which “blows out” and breaks the circuit.

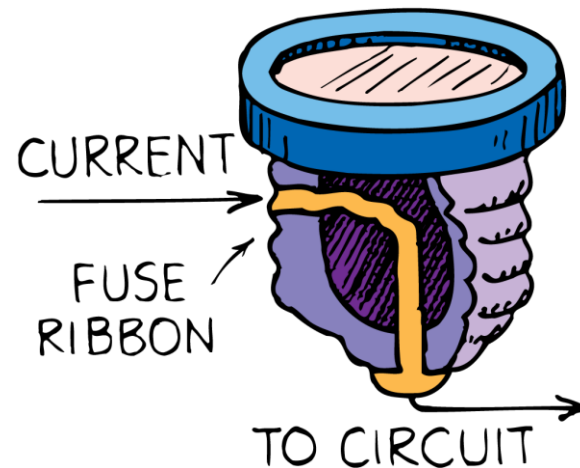



## 35.7 Parallel Circuits and Overloading

Before a blown fuse is replaced, the cause of overloading should be determined and remedied.

Insulation that separates the wires in a circuit can wear away and allow the wires to touch.

This effectively shortens the path of the circuit, and is called a *short circuit*.

A short circuit draws a dangerously large current because it bypasses the normal circuit resistance.

## 35.7 Parallel Circuits and Overloading

Circuits may also be protected by *circuit breakers*, which use magnets or bimetallic strips to open the switch.

Utility companies use circuit breakers to protect their lines all the way back to the generators.

Circuit breakers are used in modern buildings because they do not have to be replaced each time the circuit is opened.

## 35.7 Parallel Circuits and Overloading

**CONCEPT:  
CHECK:**

How can you prevent overloading in circuits?

## Assessment Questions

1. In a light bulb, the amount of current in the filament is
  - a. slightly less than the current in the connecting wires.
  - b. the same as the current in the connecting wires.
  - c. slightly greater than the current in the connecting wires.
  - d. twice as great as the current that is in the connecting wires.

## Assessment Questions

1. In a light bulb, the amount of current in the filament is
  - a. slightly less than the current in the connecting wires.
  - b. the same as the current in the connecting wires.
  - c. slightly greater than the current in the connecting wires.
  - d. twice as great as the current that is in the connecting wires.

Answer: B

## Assessment Questions

2. The flow of charge in an electric circuit is
  - a. much like the flow of water in a system of pipes.
  - b. very different from water flow in pipes.
  - c. like an electric valve.
  - d. like an electric pump.

## Assessment Questions

2. The flow of charge in an electric circuit is
  - a. much like the flow of water in a system of pipes.
  - b. very different from water flow in pipes.
  - c. like an electric valve.
  - d. like an electric pump.

Answer: A



## Assessment Questions

3. In a series circuit, if the current in one lamp is 2 amperes, the current in the battery is
- half, 1 A.
  - 2 A.
  - not necessarily 2 A, depending on internal battery resistance.
  - more than 2 A.

## Assessment Questions

3. In a series circuit, if the current in one lamp is 2 amperes, the current in the battery is
- half, 1 A.
  - 2 A.
  - not necessarily 2 A, depending on internal battery resistance.
  - more than 2 A.

Answer: B

## Assessment Questions

4. In a circuit with two lamps in parallel, if the current in one lamp is 2 amperes, the current in the battery is
- half, 1 A.
  - 2 A.
  - more than 2 A.
  - cannot be calculated from the information given

## Assessment Questions

4. In a circuit with two lamps in parallel, if the current in one lamp is 2 amperes, the current in the battery is
- half, 1 A.
  - 2 A.
  - more than 2 A.
  - cannot be calculated from the information given

Answer: C

## Assessment Questions

5. In a circuit diagram there may be
- no switches.
  - at most, one switch.
  - two switches.
  - any number of switches.

## Assessment Questions

5. In a circuit diagram there may be
- no switches.
  - at most, one switch.
  - two switches.
  - any number of switches.

Answer: D

## Assessment Questions

6. Consider a compound circuit consisting of a pair of 6-ohm resistors in parallel, which are in series with two 6-ohm resistors in series. The equivalent resistance of the circuit is
- 9 ohms.
  - 12 ohms.
  - 15 ohms.
  - 24 ohms.



## Assessment Questions

6. Consider a compound circuit consisting of a pair of 6-ohm resistors in parallel, which are in series with two 6-ohm resistors in series. The equivalent resistance of the circuit is
- 9 ohms.
  - 12 ohms.
  - 15 ohms.
  - 24 ohms.

Answer: C

## Assessment Questions

7. One way to prevent overloading in your home circuit is to
  - a. operate fewer devices at the same time.
  - b. change the wiring from parallel to series for troublesome devices.
  - c. find a way to bypass the fuse.
  - d. find a way to bypass the circuit breaker.

## Assessment Questions

7. One way to prevent overloading in your home circuit is to
- operate fewer devices at the same time.
  - change the wiring from parallel to series for troublesome devices.
  - find a way to bypass the fuse.
  - find a way to bypass the circuit breaker.

Answer: A